

### PRESSURE DROPS

The graph shows the variation in pressure drop in relation to the air volume for the different Fume Extractors. **Please note that the curves show the drop in pressure when the fume extractor arm is in normal working position.**

**An air volume of 800 cubic metres per hour is recommended for each fume extractor, for normal welding.** When choosing a fan, refer to the drop in pressure at this air volume.

### TECHNICAL DATA

Recommended air flow	800 m <sup>3</sup> /h
Ducting diameter	150/160 mm
Connection diameter	150/160 mm
Weight 1.5 m	9 kg
Weight 2 m	11 kg
Weight 3 m	13 kg
Weight 4 m H/V	16 kg
Temperature tolerance	70 °C
Noise level at hood	65 - 70 dB(A)
Material hood	Polycarbonate
Material hose	Wire-reinforced PVC
Material swivel elbow	Aluminium

Fan diagram for fans series N16, N24 and N40

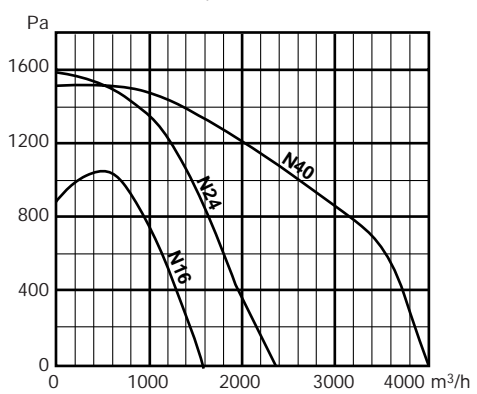

### FAN SIZING Individual Fan

Ideally, every fume extractor should have an individual fan. Experience proves that this is preferable because the fan is individually matched to the fume extractor, with regard to the air volume, thus ensuring a safe and dependable system. Add the pressure drop in the duct system, then select the fan according to the fan diagram. Recommended air volume is 800 cubic metres per hour.

### DIMENSIONING

#### System with several Fume Extractors

In a system where several fume extractors are connected to the same fan, large temporary variations in pressure drop

can occur. For this reason, it is advisable to limit the number of extractors per fan. Note: If fume extractors are to be installed in new workshops, they may be included as part of the general ventilation. In this case, all hood dampers must be left permanently open.

An example of fan sizing for a system with several arms is given below. Please note that all calculations depend on how many fume extractors operate simultaneously, and that the information is only valid for approximate sizing. **Note:** Always check that incoming air to the workshop is sufficient.

1. Draw a simple diagram showing the proposed location of each extractor.

2. Decide which model is to be used. In the example, two 4 m and two 2 m arms have been chosen.

3. The total air flow required. 800 cubic metres per hour for each arm. Add the air volume for each arm (with dampers open) in simultaneous operation (in this example 3 arms).

4. The necessary negative pressure Determine the necessary negative pressure according to the following:

- Read off the drop in pressure for the various fume extractors on the diagram on the preceding page, at 800 cubic metres per hour. The model requiring the most negative pressure will be the deciding factor.
- To this reading, add 5 Pa for every metre of duct, measured from the arm furthest away from the fan.
- Add a further 15 Pa for every 90° bend.

5. Select fan Select fan according to items 3 and 4.

6. Size the duct Size the duct according to the following values:

Air volume m <sup>3</sup> /h	Duct diameter mm
- 700	160
700 - 1400	200
1400 - 2500	250
2500 - 4000	315
4000 - 6000	400
6000 - 10000	500

Total the air volume from each fume extractor, and read off the duct size from the above table.

7. Fan and duct specification The connecting pipe from the fume extractor to the main duct should be a minimum of 160 mm in diameter.

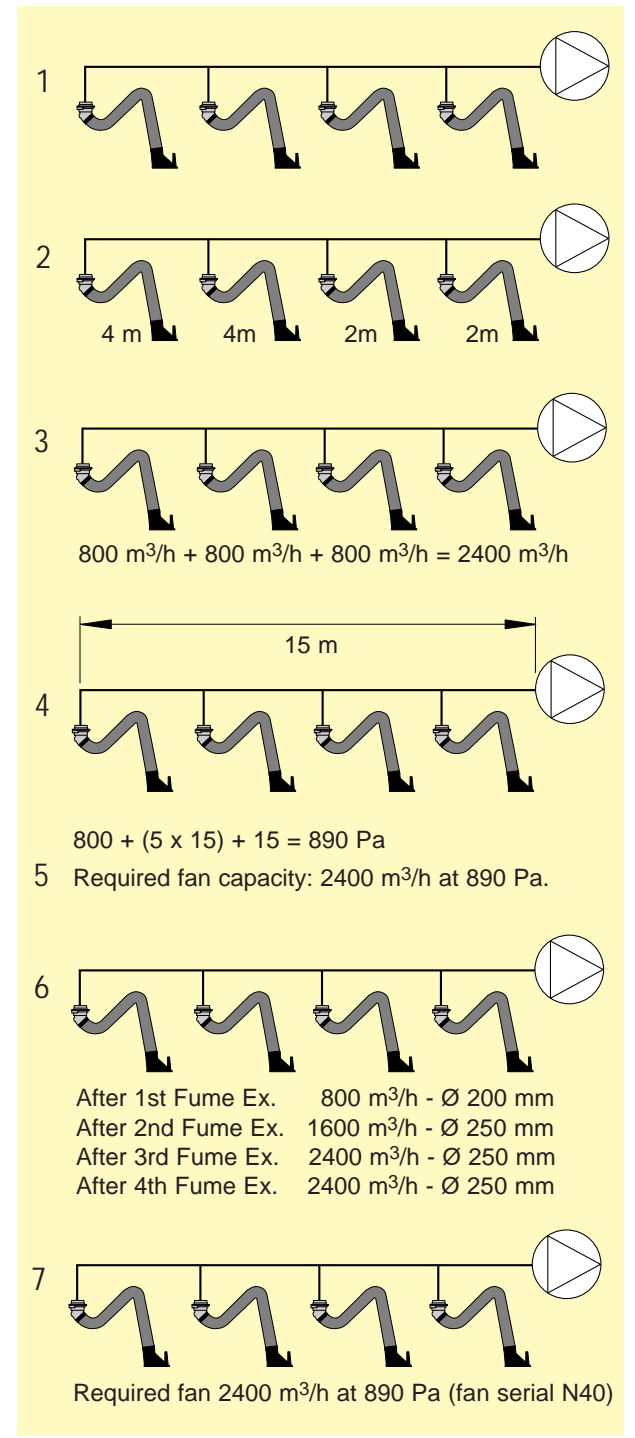

## COMBINATION POSSIBILITIES

The Fume Extractor arm can be combined with Nederman products and accessories in thousands of different ways. This essentially increases your possibilities to achieve the best solution to your capture at source problem.



The extractor arm can be equipped with a spot light and an automatic start/stop control for the fan.



If you connect several extractor arms to a central system, you should install automatic dampers to maximize fan power.

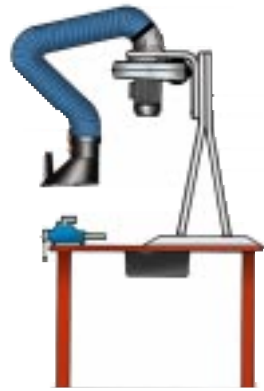

Fume Extractor with a 1-metre bracket for bench mounting.

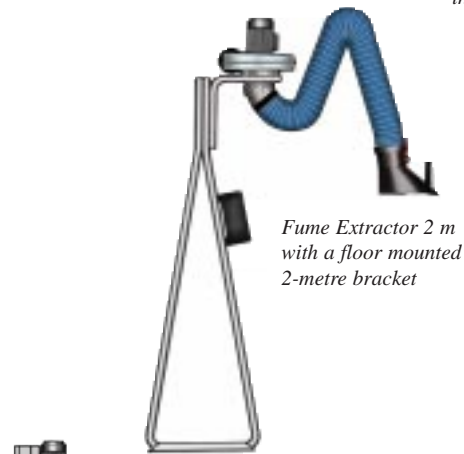

Fume Extractor 2 m with a floor mounted 2-metre bracket

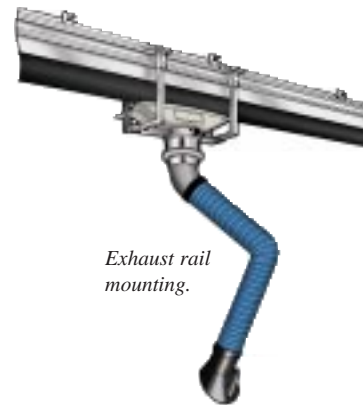

Exhaust rail mounting.



The Filtercart, a handy mobile unit with integral fan and filter. Very practical in repair shops, etc.

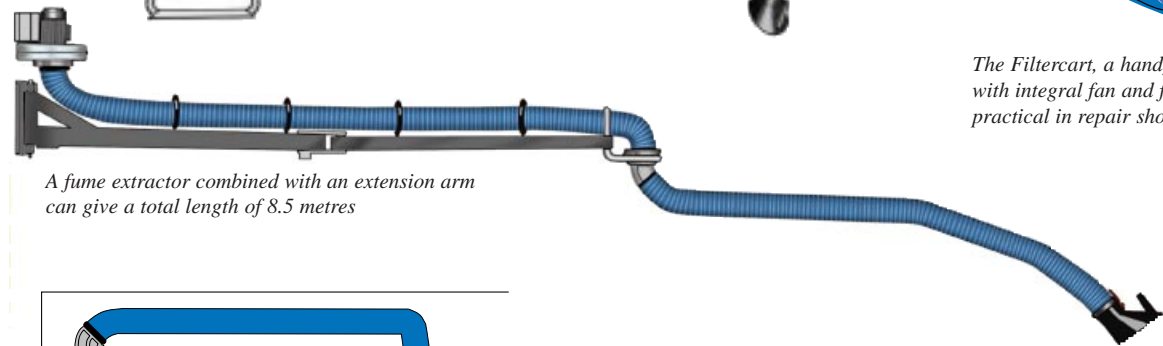

A fume extractor combined with an extension arm can give a total length of 8.5 metres

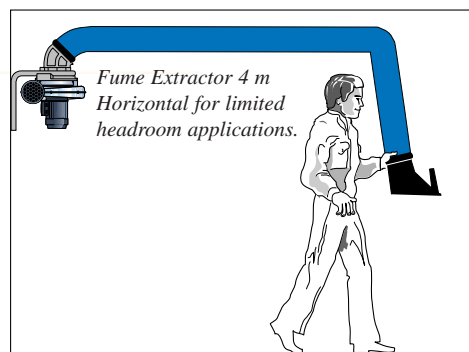

Fume Extractor 4 m Horizontal for limited headroom applications.

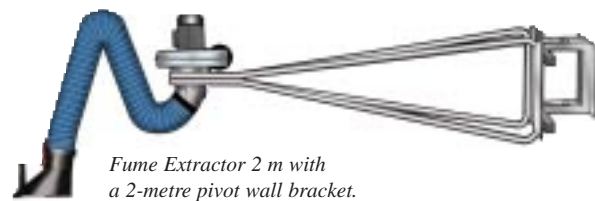

Fume Extractor 2 m with a 2-metre pivot wall bracket.

**Nederman**<sup>®</sup>

Right reserved for modification of design and measurements.

Manufacturer:  
**AB Ph. Nederman & Co**  
 Sydhamsgratan 2  
 S-252 28 Helsingborg, Sweden  
 Telephone: +46 42 18 87 00  
 Fax: +46 42 14 79 71  
 E-mail: support@nederman.se  
 Home page: www.nederman.se



No. 3230.10/01  
 1997-05-01

**Nederman**<sup>®</sup>

## TECHNICAL DESCRIPTION, NEDERMAN ORIGINAL

### GENERAL DESCRIPTION

Nederman Original Extractor Arms are designed to collect dust or fumes at source. They are available in five different models. All arms mount directly to the complete range of Nederman extraction products.

Specially designed factory adjusted friction joints allow the hood to be easily positioned at any point within the working area. Optional mounting brackets enable them to be mounted at various distances from the mounting surface.

Polluted air is extracted at a velocity up to 5 m/s (at 800 cubic metres per hour), measured at the mouth of the hood. For an even further reduction in heat loss, automatic dampers are available for the system.

### FIVE MODELS AVAILABLE

All models may be mounted on walls, ceilings, floors or workbenches. They may be connected to individual fans or to a centralized system.

V = vertical friction joint

H = horizontal friction joint

**NB!** Models 4 m V and 4 m H are equipped with an extra 4-way friction joint (2 x 240°), enabling the hood to be positioned to extract polluted air from underneath an object.

Part No. 522135

1.5 m

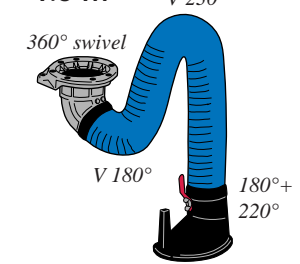

Part No. 522235

2 m

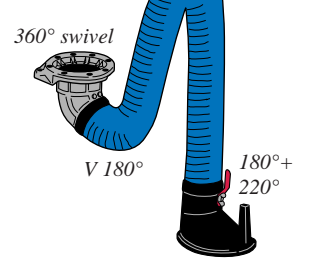

Part No. 522335

4 m V

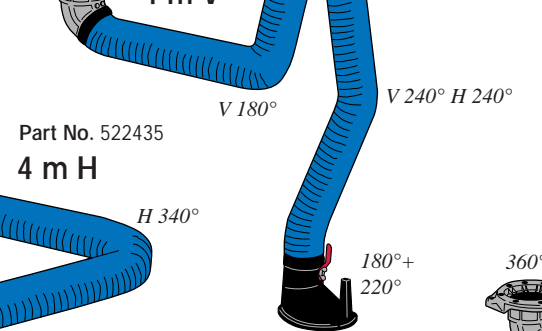

Part No. 522435

4 m H

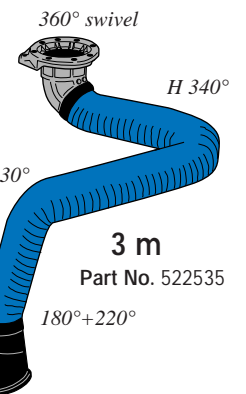
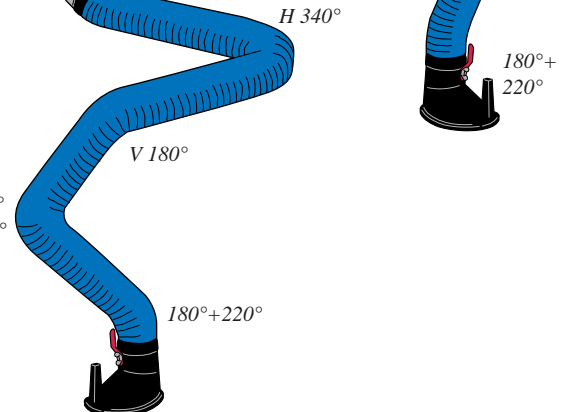

3 m

Part No. 522535

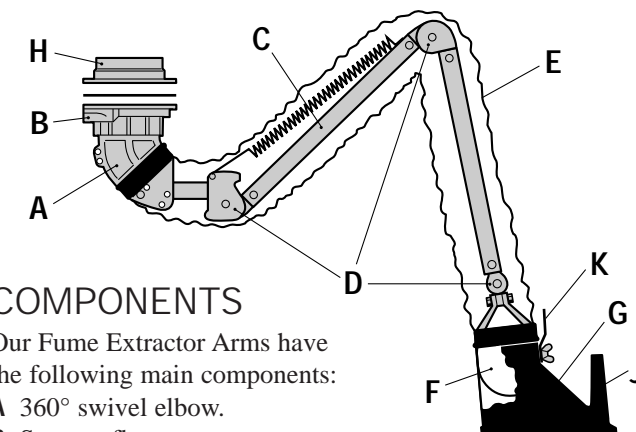

### COMPONENTS

Our Fume Extractor Arms have the following main components:

- A 360° swivel elbow.
- B Support flange.
- C Internal support.

- D Pre-set joints with wear discs, can be readjusted if required.
- E Wire reinforced PVC hose, 160 mm diam. Maximum operating temperature is 70°C.
- F Damper with positive seal.
- G Oval polycarbonate hood, 250 mm x 300 mm. Optional light package available.
- H Counter flange for ventilation duct, 150/160 mm dia. Not required with fan.
- J Handle for positioning hood.
- K Lever for regulating airflow damper.